



**AMERICAN & OHIO LOCOMOTIVE CRANE CO. INC.**

**811 Hopley Avenue  
P.O. Box 511  
Bucyrus, Ohio 44820**

800-993-6446 ~ 419-562-6010 ~ Fax: 419-562-2565 ~ [www.aolcrane.com](http://www.aolcrane.com)

---

**OEM Product Support Bulletin**

**No. 33**

**DATE:** September 17, 2013 (revision date)

**SUBJECT:** **TEMPORARY MOTOR CONNECTION**  
In case of motor failure: “Motors in Series”

**RATING:**

**DIRECTIVE**  
(Action is required)

**ALERT**  
(Potential Problem)

**INFORMATION**

**PRODUCT IMPROVEMENT**  
(Enhance Product)

**Machine Model (s):** All American & Ohio Locomotive Cranes

**Serial Numbers:** Specific per machine: For Motors Wired in Series

**Summary:** Correct way to connect up motors in case of one motor failure

**Operational Impact:**

- 1) Determine which motor is faulty
  - Motor #1 is located on the front Truck Set. (hand brake end)
  - Motor #2 is located on the rear Truck Set. (opposite hand brake end)
- 2) Disengage the gearing for the faulty motor.
- 3) Disconnect all (4) motor leads from the failed motor at the bolted lug splice located above the drive axle.
  - Heat shrink and/or tape insulation must be removed to expose these “in line” lug connections.

- 4) Insulate (with electrical tape and/or heat shrink) the leads that are coming from the motor and secure them where they will not be damaged by crane travel or other crane operation until the motor is removed for repair..
- 5) Remove motor for repair when possible and cover motor opening on Gear Case. If machine will be continued to be used with motor removed, secure a plate over the flat bearing cap (American only) that is flush with the case on the side the motor was removed from.
- 6) The remaining (4) leads (those coming to the motor from the crane collector ring area) must be connected together as follows
  - Connect the two “A” (Armature) leads together, insulate and secure.
  - Connect the two “F” (Field) leads together, insulate and secure.

1. Example: #1 End of Crane

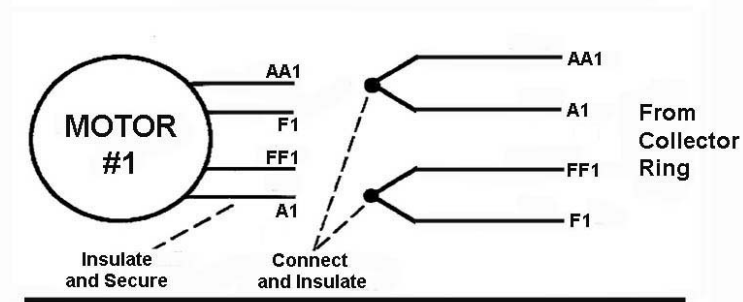

2. Example: #2 End of Crane

